

SPEC No.

ED-22G009

ISSUE : December 20 , 2022

TO ;  
\_\_\_\_\_

## S P E C I F I C A T I O N S

Product Name PHOTOINTERRUPTER

Model No. GP2A432LCSAF

These specifications contain 12 pages including the cover and appendix.

This specification sheets and attached sheets shall be both side copy.

After confirmation of the contents, please be sure to send back      copy of the Specifications with approving signature on each.

If you have any objections, please contact us before issuing purchasing order.

Accepted by:

Sharp Corporation

By: \_\_\_\_\_  
Name:  
Title:  
Date:

By: J. K  
Name: T. Kamiyoshi  
Title: Senior Manager  
Electronic Components and Devices Account Div.  
Date: Dec. 22, 2022

By: \_\_\_\_\_  
Name:  
Title:  
Date:

Sharp Semiconductor Innovation Co.,Ltd.  
By: T. O  
Name: T. Okuda  
Title: Division Manager  
Development Div.I  
Date: Dec. 22, 2022

Reviewed by:  
By: M. T  
Name: M. Tsuji  
Title: Engineer  
Date:

Prepared by:  
By: T. K  
Name: T. Kishida  
Title: Engineer  
Date:

1. These specification sheets include materials protected under copyright of Sharp Corporation ("Sharp").  
Please handle with great care and do not reproduce or cause anyone to reproduce them without Sharp's consent.

2. When using this Sharp product, please observe the absolute maximum ratings, other conditions and instructions for use described in the specification sheets, as well as the precautions mentioned below.  
Sharp assumes no responsibility for any damages resulting from use of the product which does not comply with absolute maximum ratings, other conditions and instructions for use included in the specification sheets, and the precautions mentioned below.

(Precautions)

- (1) In making catalogue or instruction manual based on the specification sheets, please verify the validity of the catalogue or instruction manuals after assembling Sharp products in customer's products at the responsibility of customer.
- (2) This Sharp product is designed for use in the following application areas ;  
  - Computers • OA equipment • Telecommunication equipment (Terminal) • Measuring equipment
  - Tooling machines • Audio visual equipment • Home appliances
 If the use of the Sharp product in the above application areas is for equipment listed in paragraphs (3) or (4), please be sure to observe the precautions given in those respective paragraphs.
- (3) Appropriate measures, such as fail-safe design and redundant design considering the safety design of the overall system and equipment, should be taken to ensure reliability and safety when Sharp product is used for equipment in responsibility of customer which demands high reliability and safety in function and precision, such as ;  
  - Transportation control and safety equipment (aircraft, train, automobile etc.)
  - Traffic signals • Gas leakage sensor breakers • Rescue and security equipment
  - Other safety equipment
- (4) Sharp product is designed for consumer goods and controlled as consumer goods in production and quality.  
Please do not use this product for equipment which require extremely high reliability and safety in function and precision, such as ;  
  - Space equipment • Telecommunication equipment (for trunk lines)
  - Nuclear power control equipment • Medical equipment
- (5) Please contact and consult with a Sharp sales representative if there are any question regarding interpretation of the above four paragraphs.

3. Disclaimer

The warranty period for Sharp product is one (1) year after shipment.  
During the period, if there are any products problem, Sharp will repair (if applicable), replace or refund.  
Except the above, both parties will discuss to cope with the problems.

The failed Sharp product after the above one (1) year period will be coped with by Sharp, provided that both parties shall discuss and determine on sharing responsibility based on the analysis results thereof subject to the above scope of warranty.

The warranty described herein is only for Sharp product itself which are purchased by or delivered to customer.  
Damages arising from Sharp product malfunction or failure shall be excepted.

Sharp will not be responsible for the Sharp product due to the malfunction or failures thereof which are caused by:

- (1) storage keep trouble during the inventory in the marketing channel.
- (2) intentional act, negligence or wrong/poor handling.
- (3) equipment which Sharp products are connected to or mounted in.
- (4) disassembling, reforming or changing Sharp products.
- (5) installation problem.
- (6) act of God or other disaster (natural disaster, fire, flood, etc.)
- (7) external factors (abnormal voltage, abnormal electromagnetic wave, fire, etc.)
- (8) special environment (factory, coastal areas, hot spring area, etc.)
- (9) phenomenon which cannot be foreseen based on the practical technologies at the time of shipment.
- (10) the factors not included in the product specification sheet.

4. Please contact and consult with a Sharp sales representative for any questions about Sharp product.



## 7. Notes

### 7.1 The circuit design

Vo terminal : Open drain output.

GP2A432LCSAF operates the light emitter by pulse drive. Please supply the stable supply voltage in order to prevent error operation by pulse current.

At power up, it takes 5 milliseconds that internal circuit becomes stable after reaching operating voltage level.

### 7.2 Prevention error operation

If the inverter light is directly incident on the light receiving surface, the circuit is designed so that the output is forced to the non-detection state, so it may not work properly.

Please be careful that you need to keep the direct inverter light away from the photo detecting surface since the device.

In addition, we recommend to make sure the operation test in the actual application.

### 7.3 Cleaning

Polycarbonate resin is used as the material of the lens surface. As to cleaning, this reflective type photointerrupter shall not be cleaned by cleaning materials absolutely. Dust and stain shall clean by air blow, or shall clean by soft cloth soaked in washing materials.

### 7.4 Plugging in/out

The connector should be plugged in/out at normal temperature.

2.1 Outline (DrawingNo. CY1558li02) Scale:2/1 Unit:1/1mm

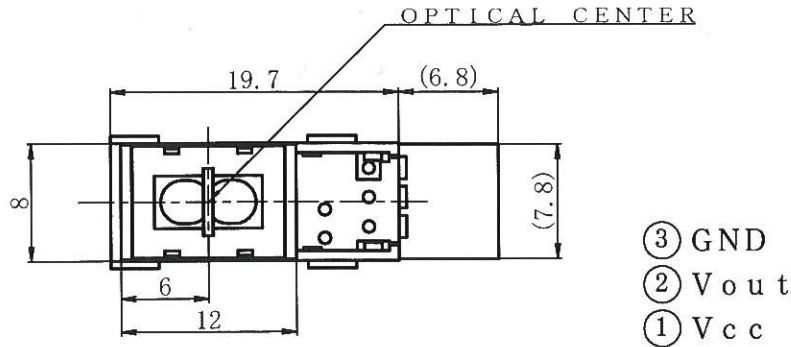

Connector : Made by Tyco Electronics Japan G.K. 292133-3  
 (Contact : Tin plating)

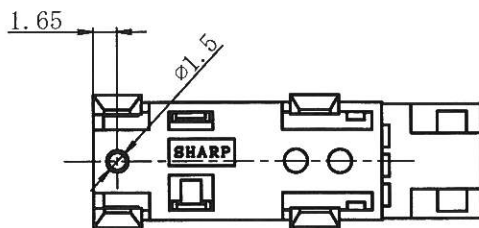
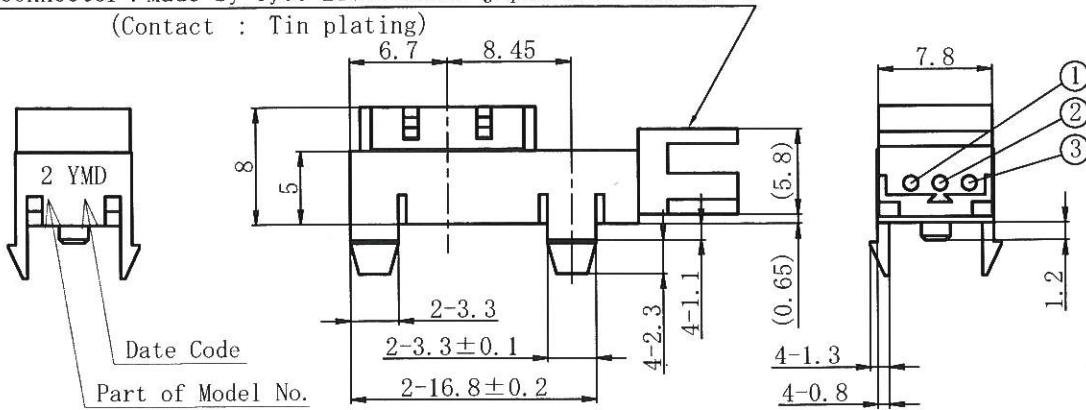

Note)

1. Unspecified tolerance shall be shown in the following list.

Dimension	Tolerance
less than 6.0	± 0. 2
6.0 or more less than 14.0	± 0. 3
14.0 or more	± 0. 4

2. Dimensions in parenthesis are shown for reference.

3. Date code

Y : Year (2022 : 2) Number of the end of the Christian era

M : Month (1~9, X, Y, Z)

D : Date (1~9, Please refer to a right list other than it.)

Date	10	11	12	13	14
Code	A	B	C	D	E
Date	15	16	17	18	19
Code	F	G	H	J	K
Date	20	21	22	23	24
Code	M	N	O	P	R
Date	25	26	27	28	29
Code	S	T	U	W	X
Date	30	31			
Code	Y	Z			

Internal connection diagram

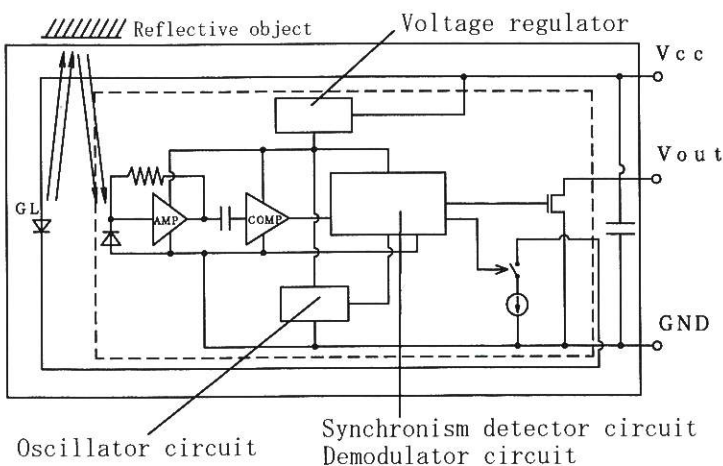

## 2.2 GP2A432LCSAF Recommended Installation Hole drawing (DrawingNo.CY15582i06) Scale:2/1 Unit:1/1mm

- \*1 We recommend to fix GP2A432LCSAF at punching side on the fixing plate(metal plate).
- \*2 Please decide the final dimensions at your side after confirmation by the actual applications, Because mounting efficiency and mounted stabilization are dependent on mounting plate corner-R and punched state.
- \*3 Tolerance shall be  $\pm 0.1\text{mm}$ .

Recommended mounting type (Thickness of plate for 1.0mm)

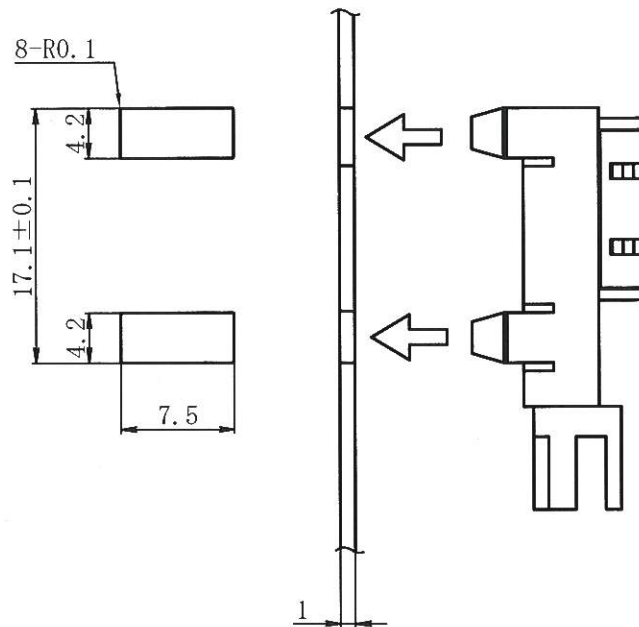

Reverse mounting protection type (Thickness of plate for 1.0mm)

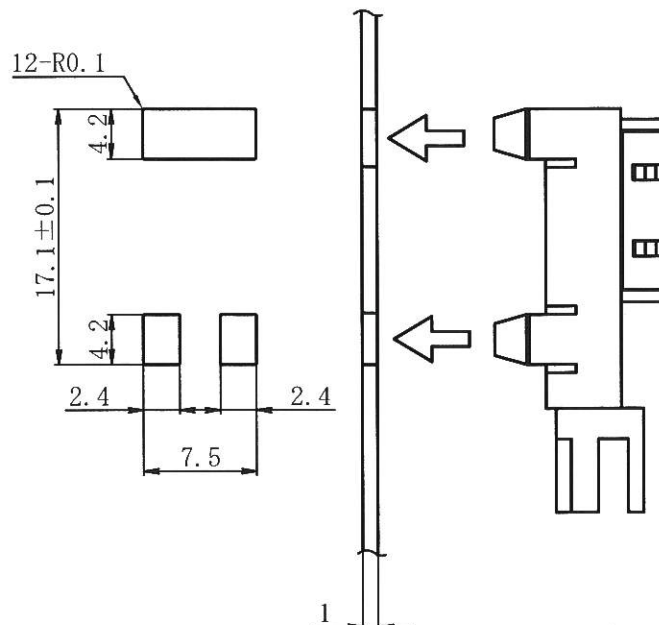

3. Ratings and characteristics

3.1 Absolute maximum ratings

Ta=25°C

Parameter	Symbol	Rating	Unit	Remark
Supply voltage	Vcc	-0.5 to +6	V	
Output current	I <sub>OL</sub>	50	mA	Sink current ※1
Operating temperature	Topr	-10 to +85	°C	The connector should be plugged in/out at normal temperature.
Storage temperature	Tstg	-20 to +85	°C	

※1 Fig.1 shows output current vs. ambient temperature.

3.2 Electro-optical characteristics

Vcc=3.3 to 5V Ta=-10 to +85°C

Parameter	Symbol	MIN.	TYP.	MAX.	Unit	Conditions
Supply voltage	Vcc	3.0	-	5.5	V	-
Current dissipation ( I )	I <sub>cc</sub>	-	-	10	mA	Smoothing value, R <sub>L</sub> =∞
Current dissipation ( II )	I <sub>ccp</sub>	-	-	250	mA	Pulse peak value *1
Low level output voltage	V <sub>OL</sub>	-	-	0.4	V	at detection time, I <sub>OL</sub> =16mA
High level output voltage	V <sub>OH</sub>	Vcc × 0.9	-	-	V	at non detection time, R <sub>L</sub> =1kΩ
Non detection distance	L <sub>LHL</sub>	-	-	22.0	mm	KODAK Gray Cards (use the white side to reflect about 90%) *2
Detection distance	L <sub>HLS</sub>	-	-	1.0	mm	KODAK Gray Cards (use the white side to reflect about 90%) *2
		-	-	3.0		Black paper *2
	L <sub>HLL</sub>	9.0	-	-	mm	KODAK Gray Cards (use the white side to reflect about 90%) *2
		7.0	-	-		Black paper *2
Response time	t <sub>PLH</sub>	-	-	1.0	ms	*3
	t <sub>PHL</sub>	-	-	1.0	ms	
Acceptable illuminance of external disturbing light	Ev1	5000	-	-	lx	*4
	Ev2	5000	-	-	lx	

\*1 Pulse peak value I<sub>ccp</sub> test method

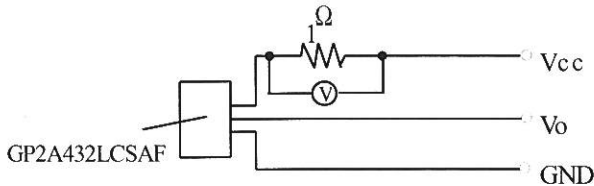

V<sub>r</sub> wave form I<sub>ccp</sub>=V<sub>r</sub> / 1 Ω

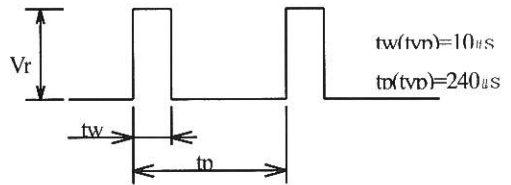

\*2 Distance characteristics test method

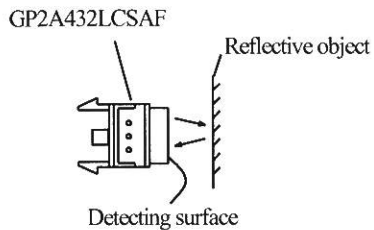

Output(pull-up resistance)

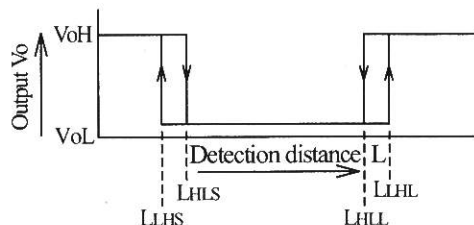

\*3 Response time test method

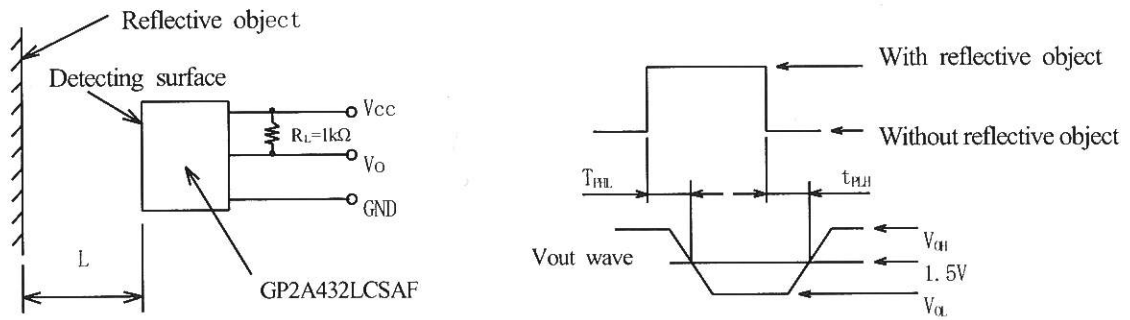

\*4 Test measurement method for acceptable illuminate of external disturbing light

E v 1 ; At non detection

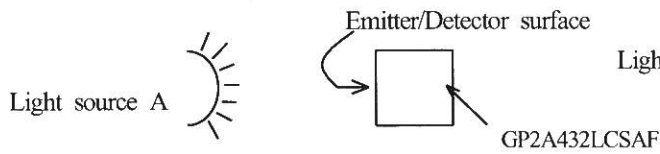

Illuminance shall be the illuminance on the emitter/detector surface.  
Output should not change "H" to "L".

E v 2 ; At detection

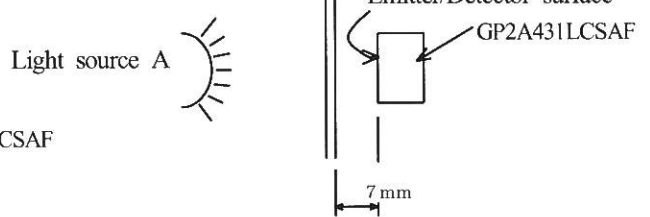

Illuminance shall be the illuminance on the emitter/detector surface.  
Output should not change "L" to "H".

Fig.1 Output current vs. ambient temperature

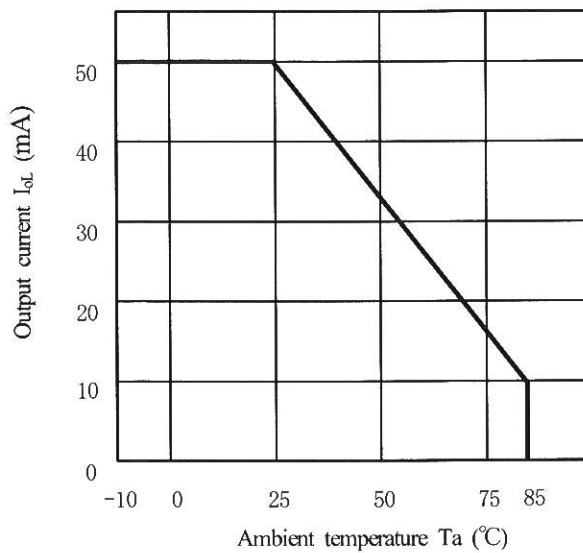



## 4. Reliability

The reliability of products shall satisfy items listed below

Confidence level : 90%

LTPD : 10 or 20

Test item	Test conditions	Failure Judgement Criteria	Samples (n)
			Defective(C)
Temperature cycling	1 cycle -20°C to +85°C (30min) (30min) 20 cycles test	$I_{cc} \geq U \times 1.2$ $V_{OL} \geq U \times 1.2$ $V_{OH} \leq L \times 0.8$  U : Upper specification limit L : Lower specification limit	n=22, C=0
High temp. and high humidity storage	+40°C, 95%R.H.* 240h		n=22, C=0
High temp. storage	+80°C, 240h		n=22, C=0
Low temp. storage	-20°C, 240h		n=22, C=0
Operation life	V <sub>cc</sub> =5V, T <sub>a</sub> =25±3°C, 1000h		n=22, C=0
Mechanical shock	1000m/s <sup>2</sup> , 3 times/ X, Y, Z direction		n=11, C=0
Variable vibration frequency	Overall amplitude ; 1.5mm Frequency range 10 to 55 to 10 Hz / 1min 2h / X, Y, Z direction		n=11, C=0
Connector strength I	Pull connector housing horizontally to connector terminal pin direction by 20N weight for 5s (1 time)		n=11, C=0
Connector strength II	Push connector housing perpendicular to connect- or terminal pin direction by 10N weight for 5s (1 time)	n=11, C=0	

\* R.H. : Relative humidity

## 5. Outgoing inspection

	Item	Conditions	Instrument	Judge, Criteria	AQL
1	Appearance	No defects that may conflict with product specifications, including crack, split, chip scratch, burr and blur, No bent connector pin and loosened pin	Visual inspection	Any of the specified defects at left is not acceptable	1.0%
2	Electrical Characteristics*	The same as specified in paragraph 3.2	Dedicated tester	Specimen that does not satisfied the requirements specified on the left-hand side is not acceptable.	0.4%

A single sampling plan, normal inspection level II based on ISO 2859 shall be adopted.

*Current consumption	————	I <sub>cc</sub>
Low level output voltage	————	V <sub>OL</sub>
High level output voltage	————	V <sub>OH</sub>
Detection characteristics	┌————	L <sub>LHL</sub>
	├————	L <sub>HLS</sub>
	└————	L <sub>HLL</sub>

## 6.2 Supplements

Parts : This product uses the below parts.

## 6.2.1 Light detector (Quantity : 1)

(Using a silicon photodiode as light detecting portion, and a CMOS IC as signal processing circuit.)

Type	Maximum sensitivity wavelength (nm)	Sensitivity wavelength (nm)	Response time ( $\mu$ s)
Photodiode	900	700 to 1200	4

## 6.2.2 Light emitter (Quantity : 1)

Type	Material	Maximum light emitting wavelength (nm)	I/O Frequency (MHz)
Infrared light emitting diode (Non-coherent)	GaAs	950	0.3

## 6.2.3 Material

Case	
Sensor base	: Black PPS resin (UL 94V-0)
Lens	: Polycarbonate resin (UL 94V-2)
Bottom cover	: Polycarbonate resin (Black) (UL 94V-2)

## 6.2.4 Others

This product shall not be proof against radiation flux.

Laser generator is not used.

6.3 Packing drawing (DrawingNo.CY15583i09)

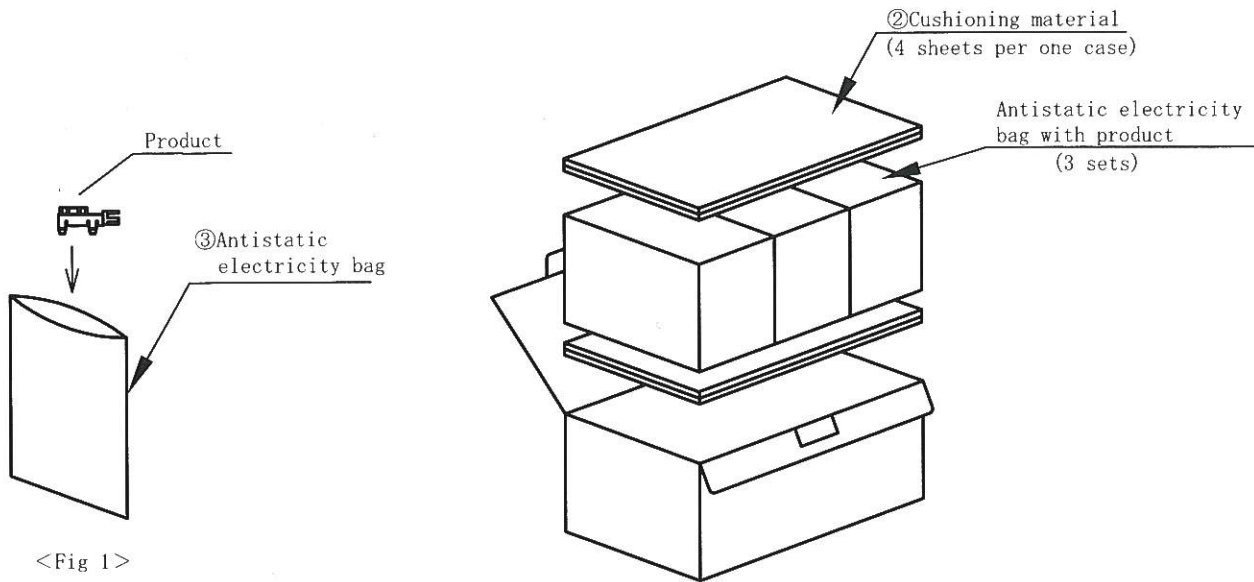

<Fig 1>

<Fig 2>

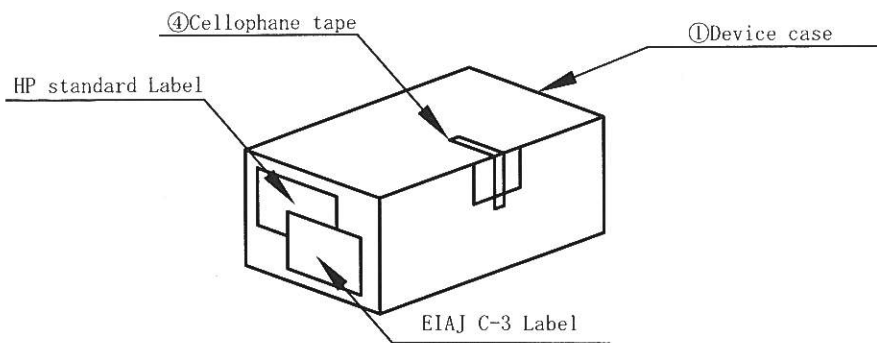

<Fig 3>

Parts composition table

No.	Name	Material	Quantity
1	Device case	Corrugated cardboard	1/300
2	Cushioning material	Urethane	4/300
3	Antistatic electricity bag	Polyethylene	1/100
4	Cellophane tape	—	—

Packing method

1. Put 100 devices into antistatic electricity bag and seal with cellophane tape. (Fig1)
2. Put three sets of a thing of above 1 to a device case.  
In addition, spread two pieces of cushioning material at top and bottom. (Fig 2)
3. Seal a device case with cellophane tape. (Fig 3)
4. Indication phase (Fig 3)  
The contents of the carton indication conforms to EIAJ C-3 and the following items are indicated.  
Model No., Internal production control name, Quantity, Packing date,  
Corporate name, Country of origin  
<Quantity : 300pcs./ packing box>  
<Mass : Approx.585g/ packing box>

• Storage condition

Packaged products shall be stored at the temperature 5 to 30°C and the humidity 70%RH or less away from direct sunlight.